

CAD FILE:

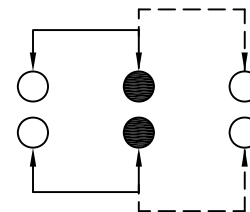

SCHEMATIC (SHORTING)

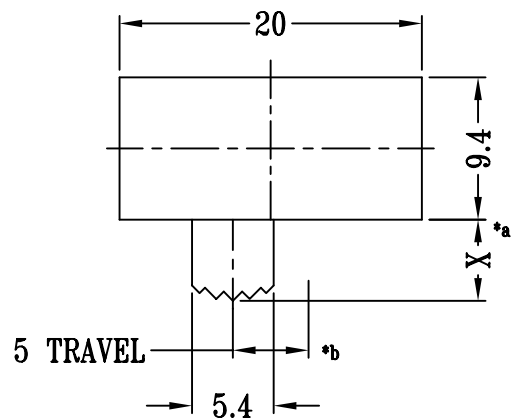
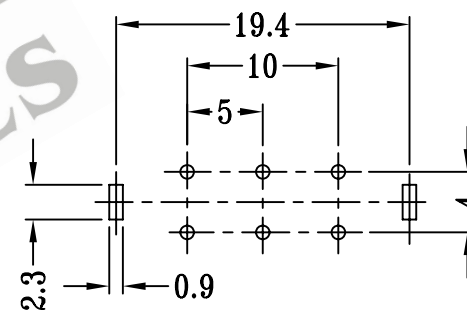
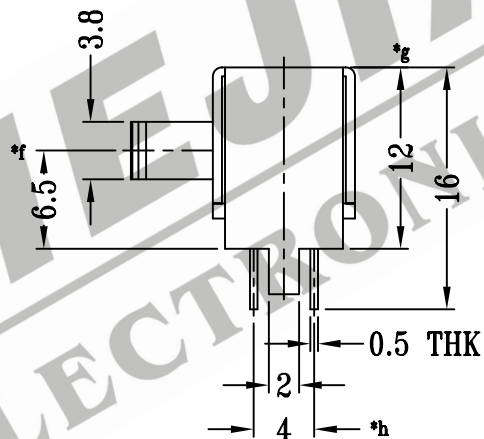
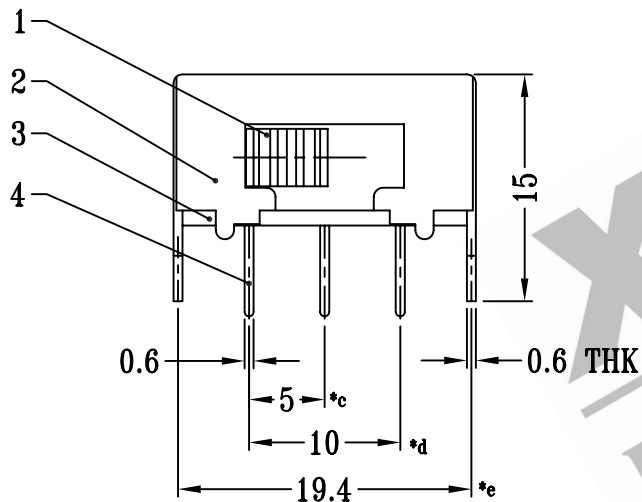

P.C.B LAYOUT

注:带\*表示关键尺寸(7个)

				TOLERANCE UNLESS SPECIFIED		SHENZHEN XIEJIA ELECTRONICS CO.,LTD.				
8										
7	STEEL BALL	STEEL	1	NATURAL						
6	SPRING	STEEL WIRE	1	TEMPER	WITHIN: 1.5±0.1mm					
5	CONTACT CLIP	PBS STRIP	2	Ag PLATED	OVER: 1.5±0.2mm	ISSUE	DATE	DESCRIPTIONS OF REVISION	APPD.	
4	TERMINAL	BRASS STRIP	6	Ag PLATED OVER Ni PLATED	TITLE : HORIZONTAL SLIDE SWITCH		UNIT : mm	DRWG NO.: XJ-DR-SK22J03-00		
3	BASE	PHENOLIC RESIN	1	NATURAL	MODEL: SK-22J03		SCALE: 2:1	DWN.	ZHOUYU	2005-9-6
2	FRAME	STEEL STRIP	1	Ni PLATED				CHK'D	FANGYING	2005-9-6
1	KNOB	POM	1	BLACK	ALL MATERIALS MUST BE COMPLIANT TO ROHS			APPD.	KANGXINAN	2005-9-6
NO.	PARTS	MATERIALS	Q'TY	FINISH						